

TIPS REINFORCING
3/8" = 1'-0"

TIPS
3" EXTERIOR CONCRETE WYTHE (COMPOSITE)
4" EPS INSULATION
2.25" INTERIOR CONCRETE WYTHE (COMPOSITE)
9.25" TOTAL THICKNESS

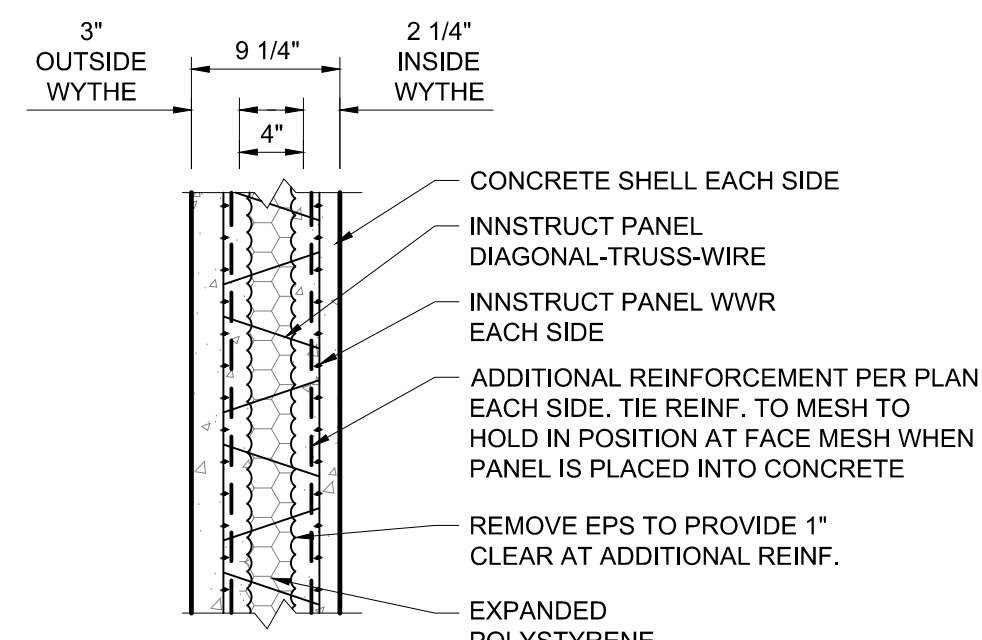

TYPICAL TIPS SECTION
SCALE: NTS

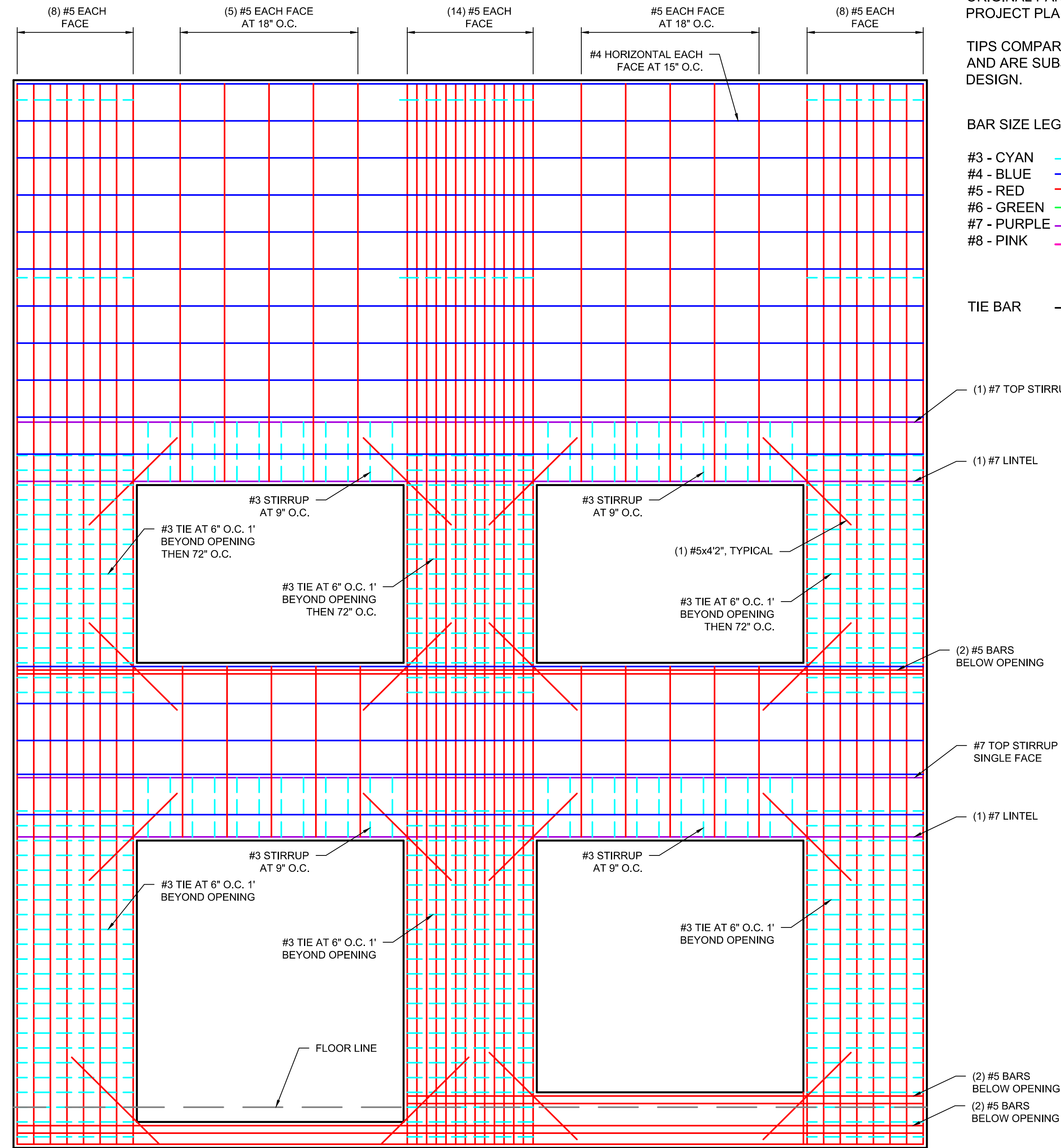

ORIGINAL PANEL REINFORCING
3/8" = 1'-0"

TILT UP PANEL
7.25" CONCRETE THICKNESS

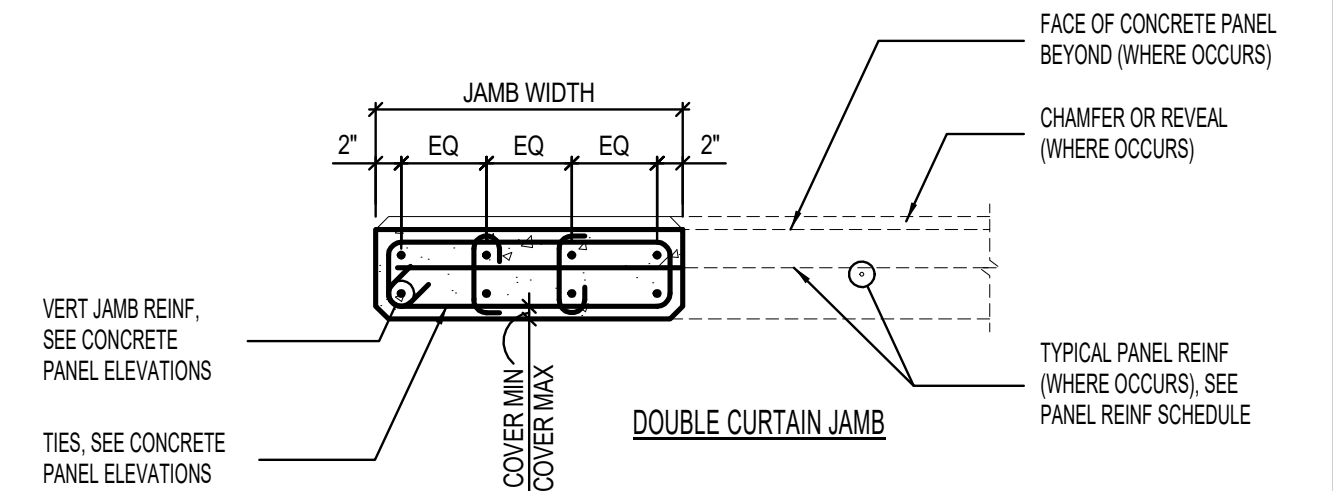

TYPICAL DOUBLE CURTAIN JAMB
SCALE: NTS

LIMITATION OF COMPARISON:
ORIGINAL PANEL DRAWINGS ARE BASED ON PROJECT PLANS

TIPS COMPARISON DRAWINGS ARE PRELIMINARY AND ARE SUBJECT TO CHANGE BASED ON FINAL DESIGN.

BAR SIZE LEGEND:

- #3 - CYAN
- #4 - BLUE
- #5 - RED
- #6 - GREEN
- #7 - PURPLE
- #8 - PINK

TIE BAR - - - - (SIZE PER COLOR)

NO.	REVISIONS	BY	DATE

FORSGREN Associates Inc.
95 WEST 100 SOUTH, STE. 115, LOGAN, UT 84321
PH: 435.227.0334 FAX: 435.227.0334

PRELIMINARY DRAWING NOT FOR CONSTRUCTION

PROJECT NO. 2
DRAWN
DESIGNED
APPROVED
DATE

INNOVATIVE STRUCTURAL SOLUTIONS

PROJECT 2A

TIPS COMPARISON

SHEET NO:

DATE: NOVEMBER 2020
PAGE NO:

INNSTRUCT | Total Integrated Panel System (TIPS)

Basic Design Comparison and Material Displacement Estimate

Project: **2A**

Prepared by:

Kim D. Blackburn

Panel Description: S100 overhead & windows

Date:

1/1/2021

Total Wall Square Feet: 23,800

Total Panels in Project: 27

Panel Configuration:

- 5 Number of Similar Panels in Project
- 36.00 Height (ft)
- 30.83 Width (ft)
- 261 Area of Openings (ft²) 2-9'x8'6", 2-9'x6'
- 849 Panel Area (ft²)
- 150 Concrete Weight (lbs./ft³)



Original Design Configuration:

0	Architectural Wythe (in)
0	Insulation (in)
7.25	Structural Wythe (in)
7.25	Concrete Thickness (in)
7.25	Total Thickness (in)
3.6	R-value Materials Only

Innstruct | TIPS Design Configuration:

3	Outside Wythe (in)
4	Insulation (in)
2.25	Inside Wythe (in)
5.25	Concrete Thickness (in)
9.25	Total Thickness (in)
22.6	R-value Materials Only

Design Comparison | Material Displacement:

Original Design

Material	Amount	Units
Concrete	19	cubic yds
Reinforcement	4,435	lbs.
Panel Weight	81,365	lbs.

TIPS Design

Amount	Units	% Reduced
14	cubic yds	28%
606	lbs.	86%
56,314	lbs.	31%

INNOVATIVE STRUCTURAL SOLUTIONS

375 East 400 North - Morgan, Utah 84050 | www.innstruct.com

BETTER PANEL | LESS EFFORT | MORE PROFIT